

Smart Energy Center



Active Safety

Up to 30% More Energy with Optimizer



Higher Yields

Up to 30% More Energy with Optimizer



Battery Ready

Up to 30% More Energy with Optimizer



Flexible Communication

WLAN, Fast Ethernet, 4G Communication Supported

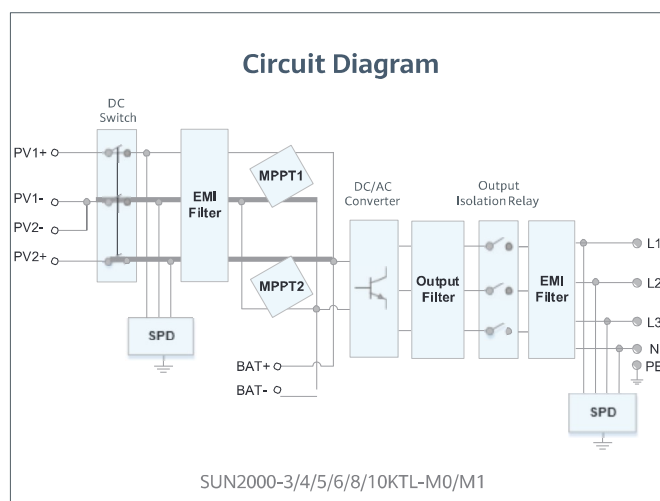
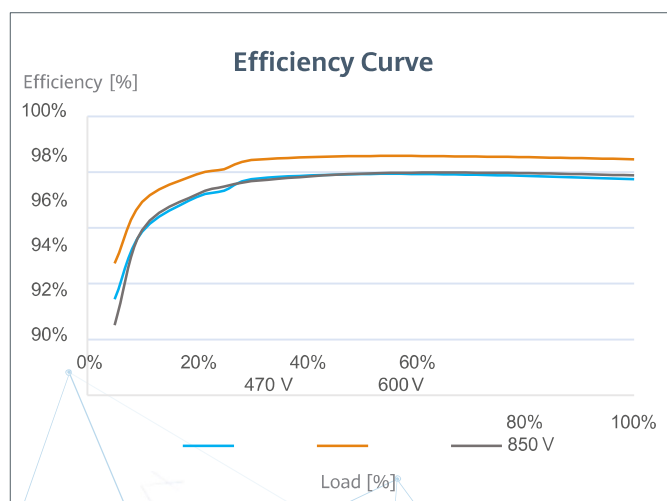

*1 Only applicable to SUN2000-3/4/5/6/8/10KTL-M1 smart energy center.
 *2. Will be compatible with HUAWEI smart string ESS in Q1, 2021



solar.huawei.com
inverter@huawei.com



photomate.eu
sales@photomate.eu

SUN2000-3/4/5/6/8/10KTL-M1 Technical Specification

Technical Specification	SUN2000-3KTL-M1	SUN2000-4KTL-M1	SUN2000-5KTL-M1	SUN2000-6KTL-M1	SUN2000-8KTL-M1	SUN2000-10KTL-M1
-------------------------	-----------------	-----------------	-----------------	-----------------	-----------------	------------------

Efficiency

Max. efficiency	98.2%	98.3%	98.4%	98.6%	98.6%	98.6%
European weighted efficiency	96.7%	97.1%	97.5%	97.7%	98.0%	98.1%

Input (PV)

Recommended max. PV power ¹	4,500 Wp	6,000 Wp	7,500 Wp	9,000 Wp	12,000 Wp	15,000 Wp
Max. input voltage ²	1,100 V					
Operating voltage range ³	140 V ~ 980 V					
Start-up voltage	200 V					
Rated input voltage	600 V					
Max. input current per MPPT	11 A					
Max. short-circuit current	15 A					
Number of MPP trackers	2					
Max. input number per MPP tracker	1					

Input (DC Battery)

Compatible Battery	HUAWEI Smart String ESS 5kWh – 30kWh					
Operating voltage range	600 V ~ 980 V					
Max operating current	16A					
Max charge Power	10,000 W					
Max discharge Power	3,300 W	4,400 W	5,500 W	6,600 W	8,800 W	10,000 W

Output (On Grid)

Grid connection	Three-phase					
Rated output power	3,000 W	4,000 W	5,000 W	6,000 W	8,000 W	10,000 W
Max. apparent power	3,300 VA	4,400 VA	5,500 VA	6,600 VA	8,800 VA	11,000 VA ⁴
Rated output voltage	220 Vac / 380 Vac, 230 Vac / 400 Vac, 3W / N+PE					
Rated AC grid frequency	50 Hz / 60 Hz					
Max. output current	5.1 A	6.8 A	8.5 A	10.1 A	13.5 A	16.9 A
Adjustable power factor	0.8 leading ... 0.8 lagging					
Max. total harmonic distortion	≤ 3 %					

Output (Backup Power via Backup Box-B1)

Maximum apparent power	3,300 VA
Rated output voltage	220 V / 230 V
Maximum output current	15 A
Power factor range	0.8 leading ... 0.8 lagging

Features & Protections

Input-side disconnection device	Yes
Anti-Islanding protection	Yes
DC reverse polarity protection	Yes
Insulation monitoring	Yes
DC surge protection	Yes, compatible with TYPE II protection class according to EN/IEC 61643-11
AC surge protection	Yes, compatible with TYPE II protection class according to EN/IEC 61643-11
Residual current monitoring	Yes
AC overcurrent protection	Yes
AC short-circuit protection	Yes
AC overvoltage protection	Yes
Arc fault protection	Yes
Ripple receiver control	Yes
Integrated PID recovery ⁵	Yes
Battery reverse charging from grid	Yes

General Data

Operating temperature range	-25 ~ + 60 °C (-13 °F ~ 140 °F)
Relative operating humidity	0 %RH~ 100 %RH
Operating altitude	0 ~ 4,000 m (13,123 ft.) (Derating above 2000 m)
Cooling	Natural convection
Display	LED Indicators; Integrated WLAN + FusionSolar App
Communication	RS485; WLAN/Ethernet via Smart Dongle-WLAN-FE; 4G / 3G / 2G via Smart Dongle-4G (Optional)
Weight (incl. mounting bracket)	17 kg (37.5 lb)
Dimension (incl. mounting bracket)	525 x 470 x 146.5 mm (20.7 x 18.5 x 5.8 inch)
Degree of protection	IP65

Optimizer Compatibility

DC MBUS compatible optimizer	SUN2000-450W-P
------------------------------	----------------

Standard Compliance (more available upon request)

Certificate	EN/IEC 62109-1, EN/IEC 62109-2, IEC 62116
Grid connection standards	G98, G99, EN 50438, CEI 0-21, VDE-AR-N-4105, AS 4777, C10/11, ABNT, UTE C15-712, RD 1699, TOR D4, NRS 097-2-1, IEC61727, IEC62116, DEWA 2.0

¹ Inverter max input PV power is 20,000 Wp when long strings are designed and fully connected with SUN2000-450W-P power optimizers.

² The maximum input voltage is the upper limit of the DC voltage. Any higher input DC voltage would probably damage inverter.

³ Any DC input voltage beyond the operating voltage range may result in inverter improper operating.

⁴ C10 / 11: 10,000VA

⁵ SUN2000-3-10KTL-M1 raises potential between PV- and ground to above zero through integrated PID recovery function to recover module degradation from PID. Supported module types include: P-type (mono, poly).